

Sc

KEY STAGE  
3

TIER  
3–6

2001

# Science test

## Paper 2

Please read this page, but do not open the booklet until your teacher tells you to start. Write your name and the name of your school in the spaces below. If you have been given a pupil number, write that also.

First name \_\_\_\_\_

Last name \_\_\_\_\_

School \_\_\_\_\_

Pupil number

--	--	--	--	--	--

### Remember

- The test is 1 hour long.
- You will need: pen, pencil, rubber, ruler, protractor and calculator.
- The test starts with easier questions.
- Try to answer all of the questions.
- Write all your answers on the test paper – do not use any rough paper.
- Check your work carefully.
- Ask your teacher if you are not sure what to do.

For marker's  
use only

Total marks	
Borderline check	

1. An actor is on a stage in a theatre. A spotlight is shining on him.

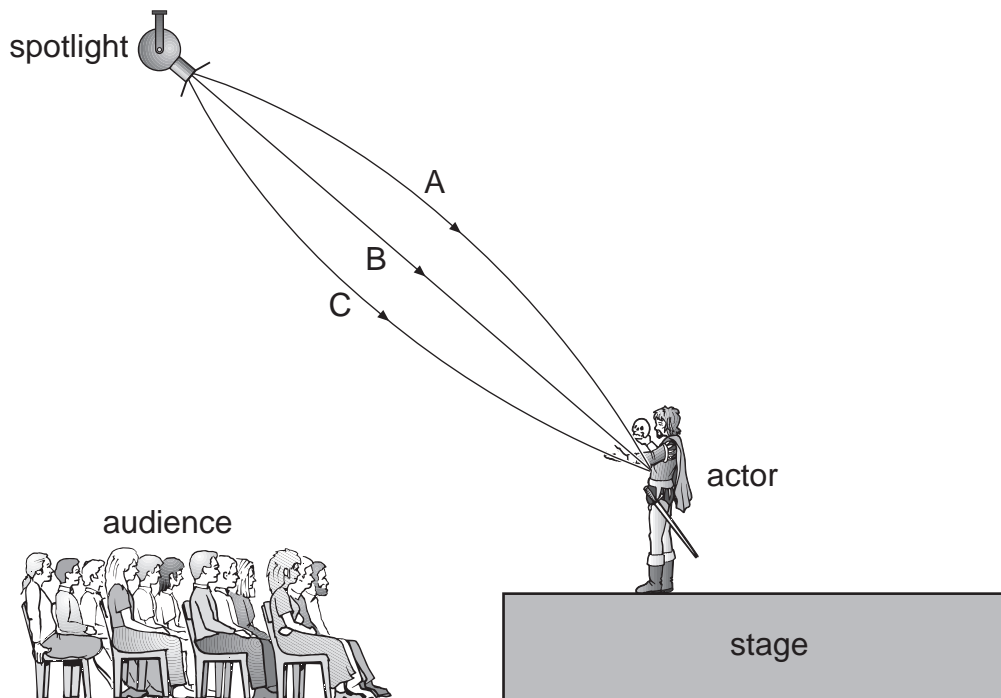

(a) A ray of light travels from the spotlight to the actor.

(i) Which line shows the ray? Give the correct letter.

1 mark

\_\_\_\_\_

(ii) How long does the light take to travel from the spotlight to the actor?  
Tick the correct box.

1 mark

about a hundred millionth of a second

about a tenth of a second

about a second

about ten seconds

---

(b) The actor's voice sounds different to the people in the front and back rows of the audience.

(i) How does the actor's voice sound different to a person in the back row?

1 mark

---

---

(ii) Complete the sentence with **longer**, **shorter** or **exactly the same**.

1 mark

When the actor is at the back of the stage, the time his voice takes to reach the audience is \_\_\_\_\_ .

maximum 4 marks

---

2. Ali made a cat-flap to fit into a door.

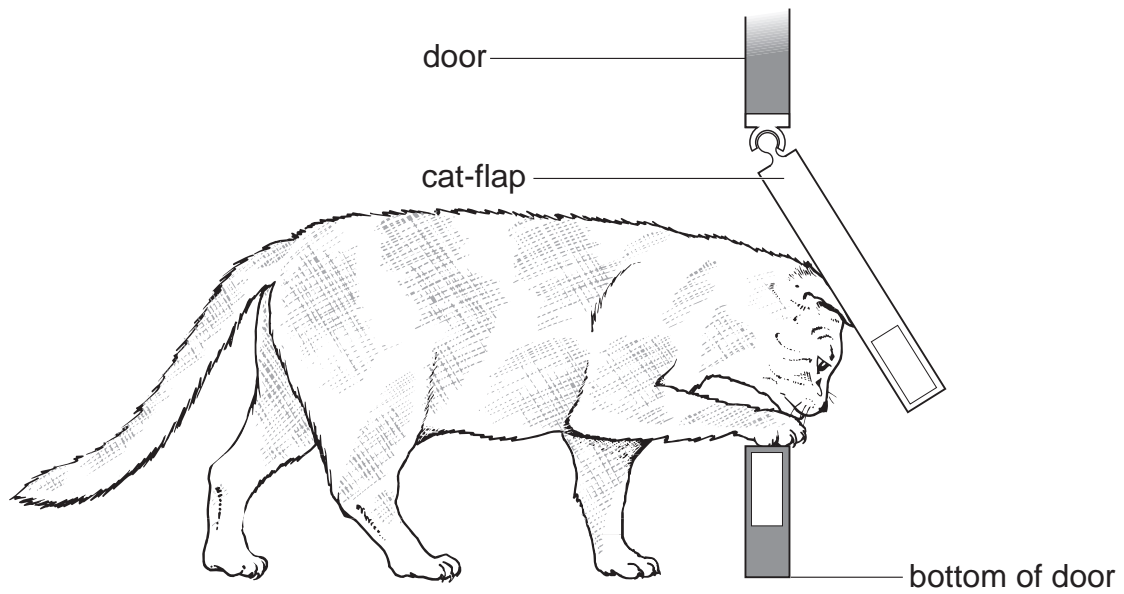

- (a) (i) On the diagram above, draw an arrow to show the direction of the force of the cat's head on the cat-flap.

1 mark

- (ii) Add a label to the diagram to show the pivot of the cat-flap. Label it P.

1 mark

When the cat has gone through the cat-flap, the weight of the cat-flap makes the flap close.

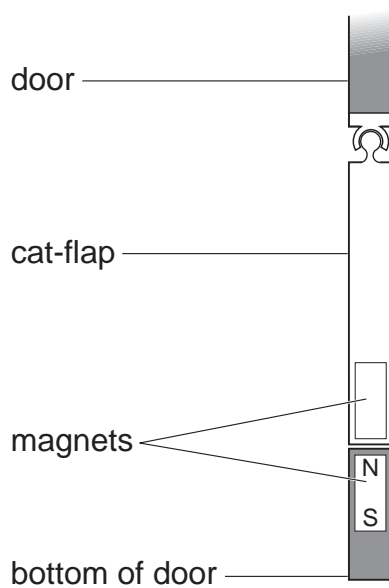

- (b) Ali used two bar magnets to keep the cat-flap closed, so that it does **not** blow open in the wind.

On the diagram above, label **both** the North and South poles on the magnet in the cat-flap.

1 mark

- (c) Friction at the pivot made the cat-flap squeak. What could Ali put on the pivot to make the friction less?

1 mark

\_\_\_\_\_

maximum 4 marks



3. Sound levels are measured in decibels (dB).  
The graph shows the recommended maximum times people should listen to sounds of different levels.  
At longer times there could be serious damage to hearing.

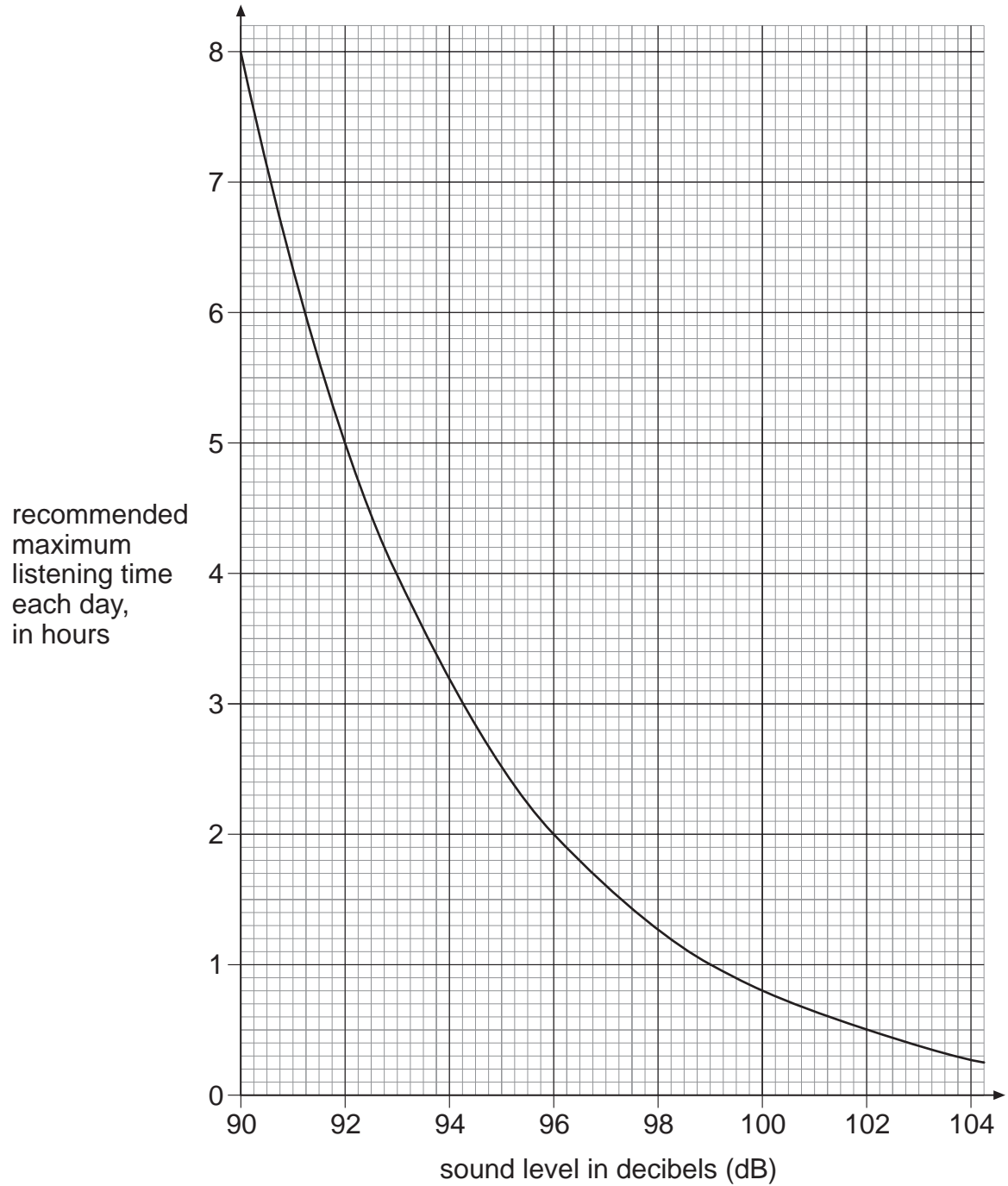

- (a) What is the maximum time each day for listening to a personal stereo at 96 dB?

\_\_\_\_\_ hours

1 mark

---

(b) In what way could a sound of more than 120 dB damage the ear?

1 mark

---

(c) (i) Sally works for five hours in a nightclub. What should the maximum sound level be in the nightclub so that her hearing is **not** damaged? Use the graph to find your answer.

1 mark

\_\_\_\_\_ dB

(ii) How can ear plugs protect Sally's ears?

1 mark

---

---

maximum 4 marks



- 
4. The photograph shows two rubber tyres.  
One is old and worn and the other is new.



old tyre with  
worn tread

new tyre with  
deep tread

- (a) A car is moving along a road. What force between the tyres and the road makes the car stop? Tick the correct box.

1 mark

air resistance

friction

gravity

weight

- (b) The diagram and the table show the stopping distance of a car.



type of road surface	stopping distance, in metres			
	new tyres on a dry road	new tyres on a wet road	old, worn tyres on a dry road	old, worn tyres on a wet road
smooth tarmac	18	19	20	50
rough tarmac	13	18	17	23
concrete	12	17	16	21

- (i) What happens to the stopping distance when a road gets wet?

1 mark

\_\_\_\_\_

- (ii) Why does the stopping distance change when a road gets wet?

1 mark

\_\_\_\_\_

\_\_\_\_\_

- (iii) What happens to the stopping distance as tyres get old and worn?

1 mark

\_\_\_\_\_

- (iv) What is the safest type of road surface in the table?

1 mark

\_\_\_\_\_

maximum 5 marks



5. Water from red cabbage can be used to find out if a liquid is acidic, alkaline or neutral.

type of liquid added to the cabbage water	colour of the cabbage water
acidic	red
alkaline	blue
neutral	purple

John added three different liquids to the cabbage water.

- (a) Use the information above to complete the table below.

3 marks

liquid added to the cabbage water	colour of the cabbage water	Is the liquid acidic, alkaline or neutral?
water	purple	
lemon juice		acidic
washing up liquid	blue	

- (b) What word describes chemicals which change colour in acids or alkalis?  
Tick the correct box.

1 mark

filters  indicators   
liquids  solids

maximum 4 marks

6. A Japanese volcano erupted in 1936. Molten sulphur poured out of the volcano. When it cooled it formed rock sulphur.

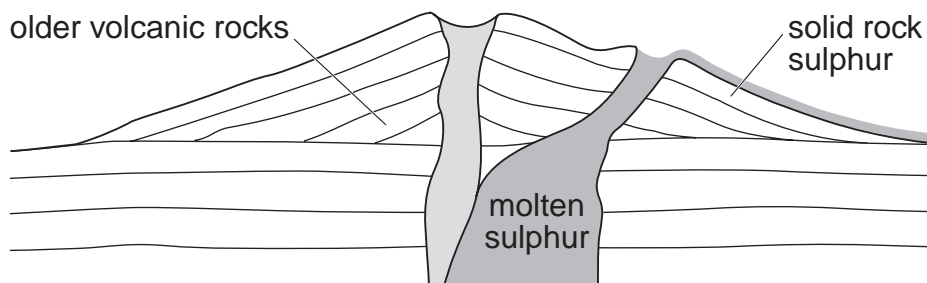

- (a) (i) Which word describes molten rock that is underground?  
Choose from **lava** or **magma** or **oil**.

1 mark

\_\_\_\_\_

- (ii) Which type of rock do volcanoes produce?  
Choose from **igneous** or **metamorphic** or **sedimentary**.

1 mark

\_\_\_\_\_

- (b) Sulphur is a **non**-metallic element. It is yellow and melts at 115°C. Complete the sentences about sulphur.

- (i) Sulphur is a poor conductor of

1 mark

\_\_\_\_\_

- (ii) At 115°C sulphur changes from

2 marks

a \_\_\_\_\_ into a \_\_\_\_\_

- (c) Sulphur burns in air to form an oxide.  
What gas in the air reacts with sulphur when it burns?

1 mark

\_\_\_\_\_

maximum 6 marks



---

7. Gravy powder contains:

- a brown substance to make the gravy brown;
- cornflour to make the gravy thick.

Dan mixed some gravy powder with cold water in a beaker.  
An hour later, the contents of the beaker looked like this:

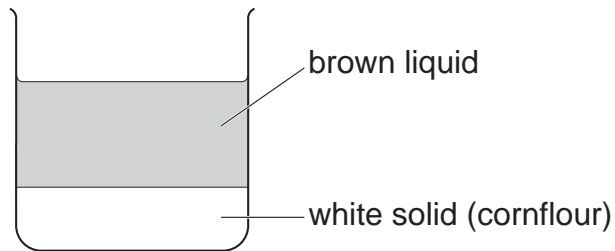

(a) Use the words in the list below to fill the gaps in the following sentences.

**solvent      solution      soluble      insoluble**

The brown substance dissolves in water to form a

brown \_\_\_\_\_ .

*3 marks*

The cornflour settles at the bottom of the beaker because

it is \_\_\_\_\_ in water.

Water is the \_\_\_\_\_ in this experiment.

(b) Dan wanted to separate the brown liquid from the white solid.  
What could he do to separate them?

*1 mark*

\_\_\_\_\_

(c) Dan put a little of the brown liquid in a dish. The next day there was  
only a brown solid left in the dish. What had happened to the water?

*1 mark*

\_\_\_\_\_

\_\_\_\_\_

- (d) Dan wanted to get pure water from the rest of the brown liquid. He set up the apparatus shown below.

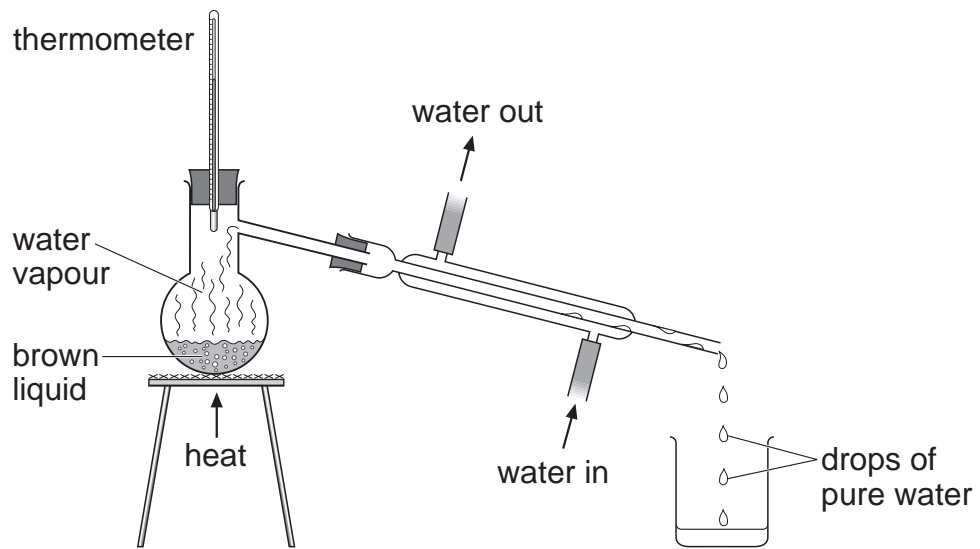

Water vapour from the brown liquid changed into drops of pure water which were collected in the beaker. What process caused the drops of water to form from the vapour? Tick the correct box.

1 mark

boiling	<input type="checkbox"/>	condensing	<input type="checkbox"/>
dissolving	<input type="checkbox"/>	melting	<input type="checkbox"/>

maximum 6 marks

8. (a) Alex poured some pond water into three beakers. She then put waterweed into each beaker. She put the beakers in different places.

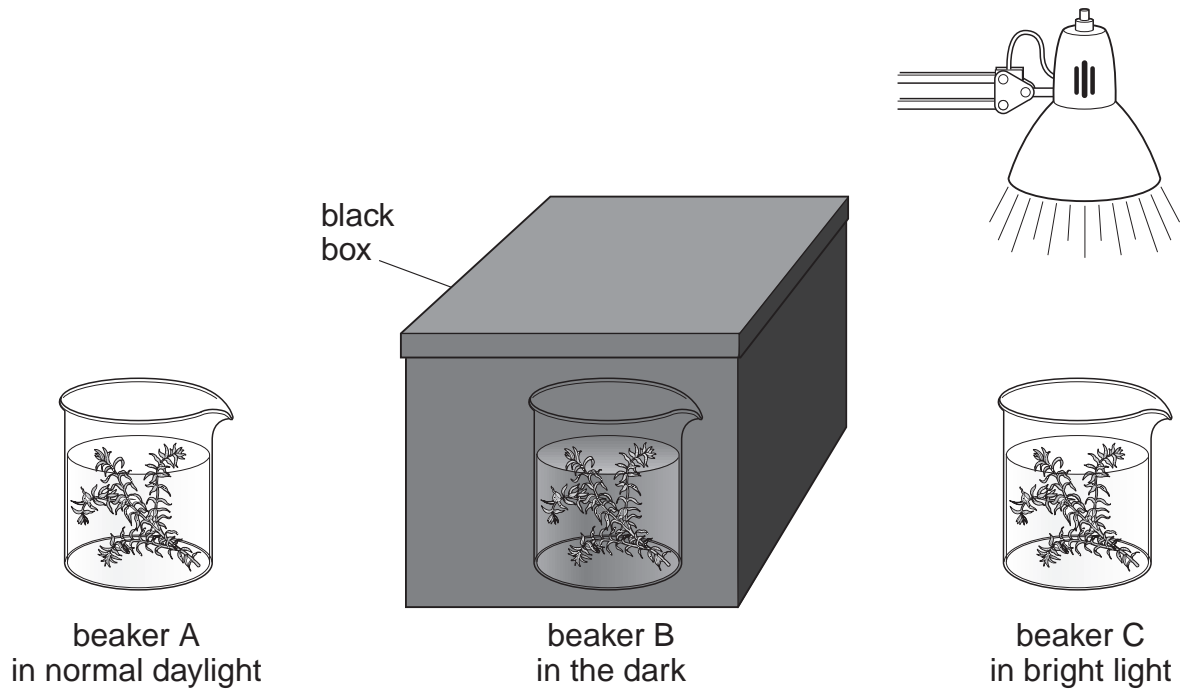

- (i) In which beaker did the waterweed grow best? Give the correct letter.

1 mark

\_\_\_\_\_

- (ii) The waterweed in the box changed from dark green to pale yellow. Why did this happen?

1 mark

\_\_\_\_\_

- (b) In the school pond there were lots of water lilies with large leaves covering the surface. There were **not** many plants growing below the surface. Suggest a reason for this.

1 mark

\_\_\_\_\_

\_\_\_\_\_

- (c) In another experiment, Alex put similar pieces of waterweed into two more beakers of pond water. She added fertiliser to one of them. She kept them both by a window.



beaker D  
containing  
waterweed and  
pond water



beaker E  
containing  
waterweed and  
pond water  
plus fertiliser

- (i) Alex added fertiliser to beaker E. Suggest the results of this experiment.

1 mark

---

---

- (ii) What do fertilisers contain to help plants grow?  
Tick the correct box.

1 mark

fat

minerals

sand

sugar

maximum 5 marks

9. The card shows the amounts of fat and fibre in some types of food and drink from a café.

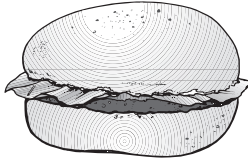
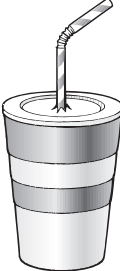
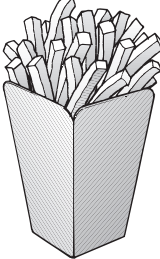
<b>Chez Jean Café</b>			
	<b>fat in g</b>	<b>fibre in g</b>	
<b>type of burger</b>			
single burger	17	0.8	
double burger	38	1.2	
cheeseburger	21	1.0	
<b>type of drink</b>			
strawberry milkshake	8	0	
medium cola	0	0	
medium orange juice	0	0	
<b>type of potato</b>			
regular fries	15	3	
baked potato	0	9	

(a) From the card opposite, choose a meal consisting of a burger, a drink and some potato, to give:

(i) the least fat; 1 mark

(ii) the most fibre. 1 mark

Write your answers in the table below.

food and drink	meal with the least fat	meal with the most fibre
type of burger		
type of drink		the drinks do <b>not</b> contain fibre
type of potato		

(b) Draw a line from each nutrient to the main reason why it is needed.  
Draw only **four** lines.

4 marks

nutrient	main reason why the nutrient is needed
calcium ●	● to keep the intestine working properly
fibre ●	● for healthy teeth and bones
protein ●	● for insulation
sugar ●	● to provide energy
	● for growth and repair

*maximum 6 marks*

6

10. The drawing shows a hairdryer.

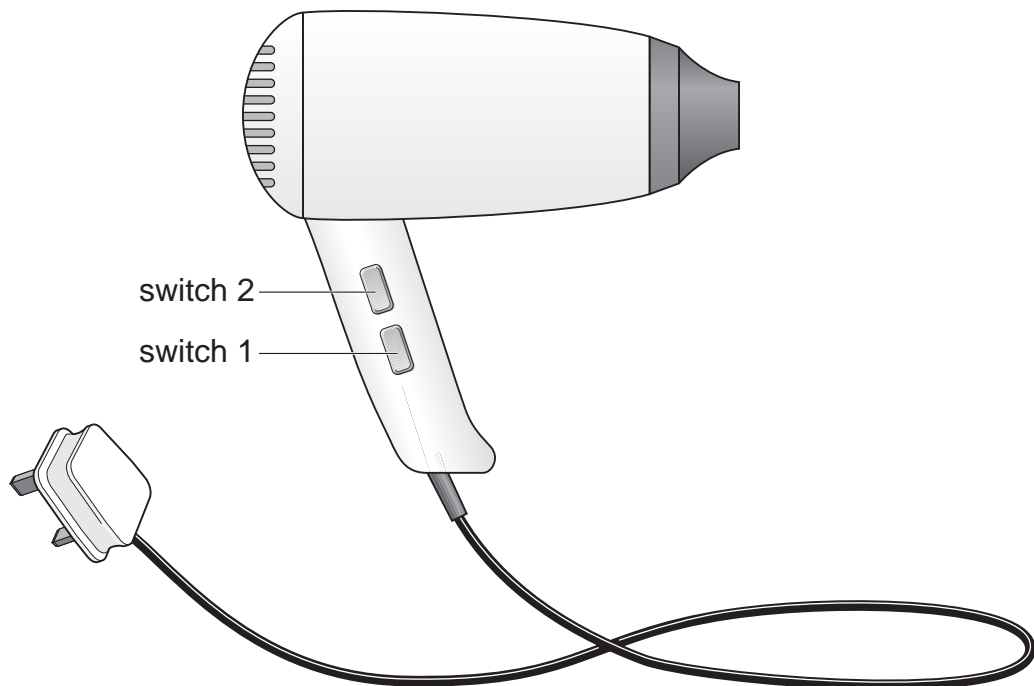

Ben drew the diagram below to show the circuit of the hairdryer.

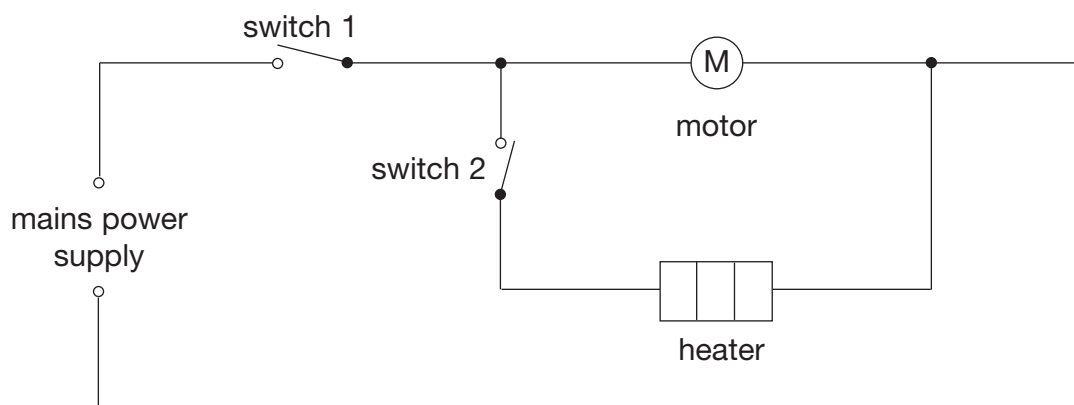

(a) Which of the switches must be closed for the heater to work?  
Tick the correct box.

1 mark

switch  
1 only

switch  
2 only

switches  
1 and 2

neither switch  
1 nor 2

- 
- (b) With this circuit, is it possible to have the heater on when the motor is switched off?

1 mark

\_\_\_\_\_

Explain your answer.

\_\_\_\_\_

\_\_\_\_\_

- (c) The motor and the heater are both on. The motor blows air through the hairdryer. If the motor breaks, what would happen to the temperature of the hairdryer?

1 mark

\_\_\_\_\_

- (d) The motor and the heater are both on. Suddenly the wire in the heater breaks. What effect, if any, will this have on the motor?

1 mark

\_\_\_\_\_

maximum 4 marks



- 
11. The diagram shows the orbits of the Earth, Mars and Venus. The position of the Earth is shown.

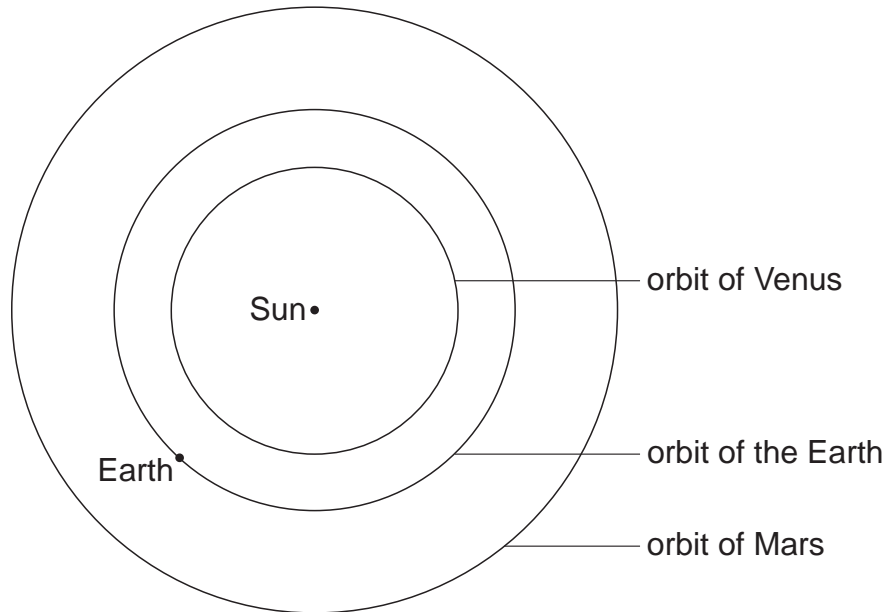

*not to scale*

A person on the Earth observes Mars and Venus.

- (a) (i) On the diagram above, draw **two** more dots to show the positions of Mars and Venus when they are closest to the Earth. Label the dot for Mars with a letter M and the dot for Venus with a letter V.

*1 mark*

- (ii) Why is it easiest to see Mars when it is closest to the Earth?

*1 mark*

---

---

- (b) What force keeps the Earth in its orbit and stops it flying off into space?

*1 mark*

---

- (c) From the Earth, the Moon always looks approximately the same size. What can you conclude from this about the orbit of the Moon around the Earth?

*1 mark*

---

---

(d) The diagram shows the Earth in its orbit around the Sun.

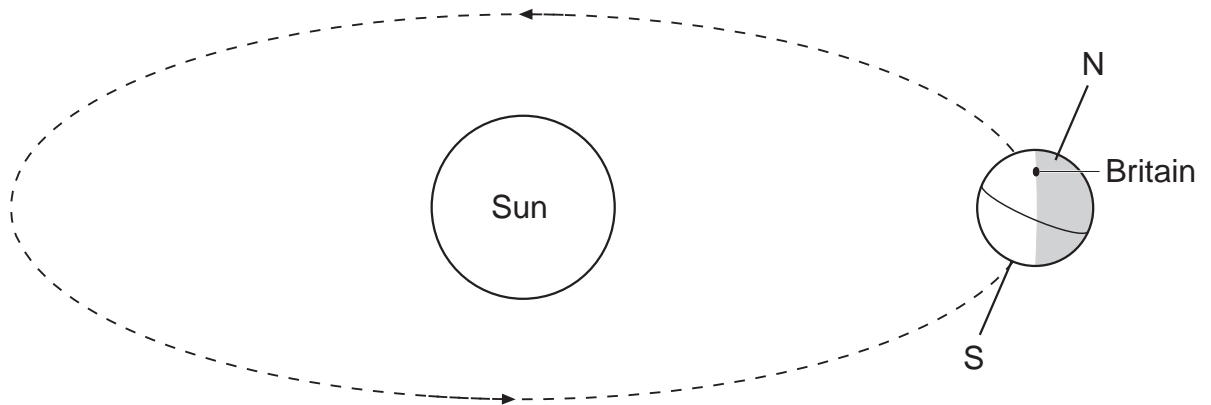

*not to scale*

What season is it in Britain? Explain your answer.

*2 marks*

---

---

---

---

*maximum 6 marks*

12. The diagram below shows the shapes and positions of five glass objects.

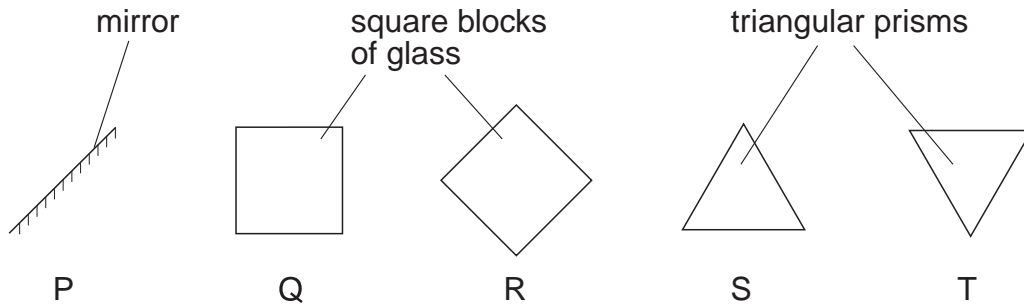

Harriet put a square of black card on top of each glass object. She shone a ray of red light onto each object.

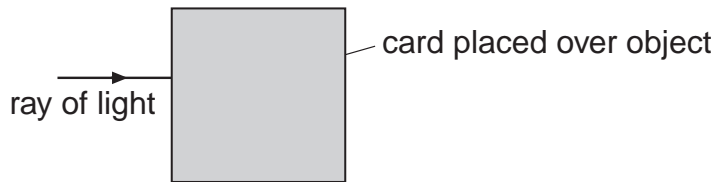

The diagrams below show the rays of light going under the cards and coming out again.

Which object is under each card? Write the correct letter below each diagram. One has been done for you.

4 marks

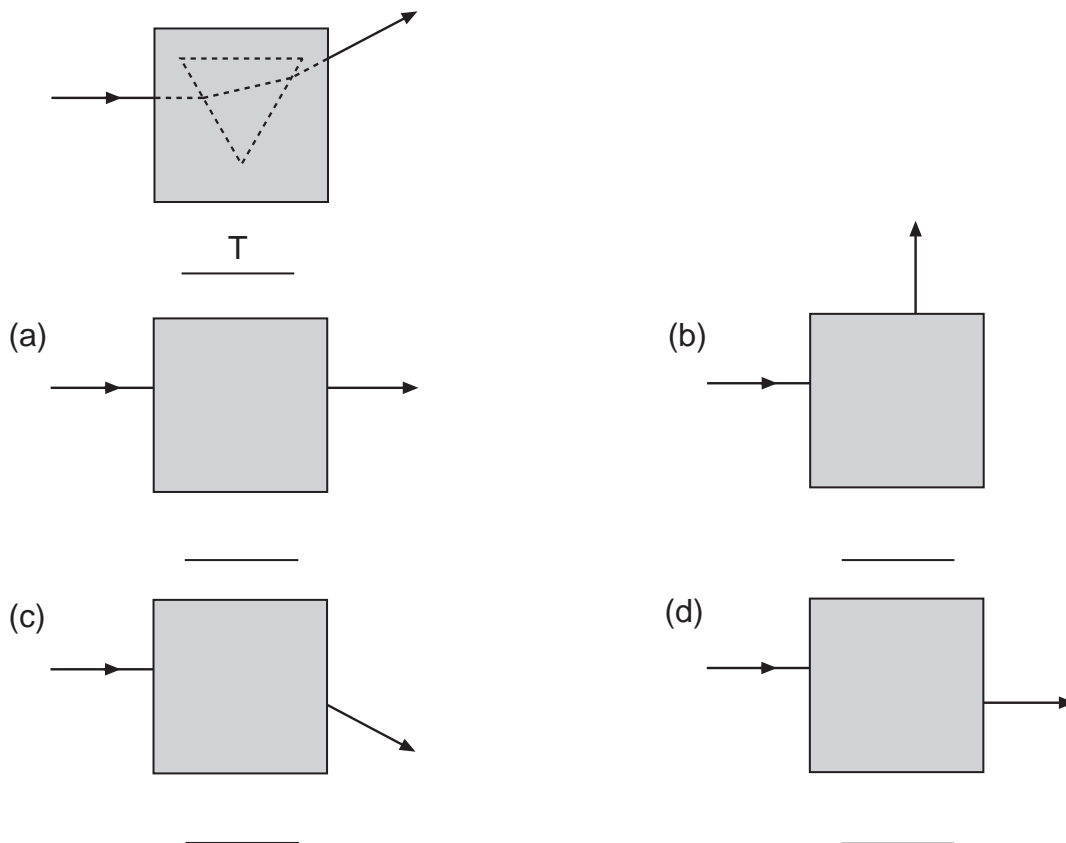

maximum 4 marks

13. Marie mixed 5 g of carbon with 5 g of lead oxide.  
She heated the mixture strongly for 15 minutes in a fume cupboard.

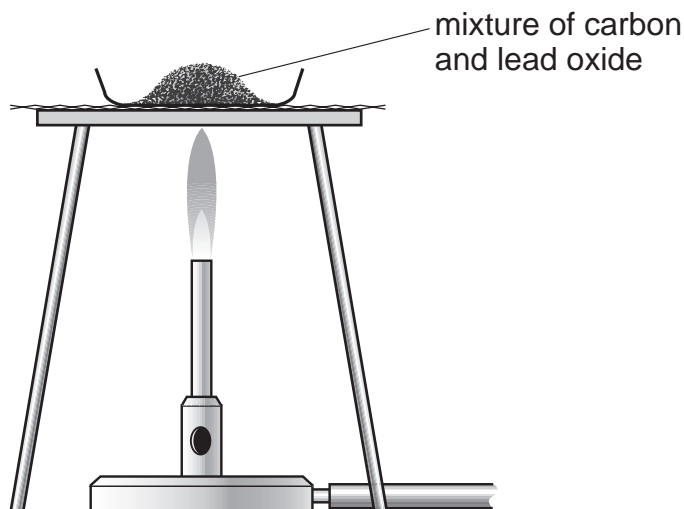

After 15 minutes, Marie found some shiny beads in the mixture.

- (a) (i) Marie collected all the shiny beads from this experiment.  
How could she test them to show they were metal?

1 mark

---

---

- (ii) Marie's test showed that the tiny beads were metal.  
What metal were the beads likely to be?

1 mark

---

- (b) Marie also expected carbon dioxide to be formed in this experiment.

- (i) In carbon dioxide, what element is combined with carbon?

1 mark

---

- (ii) Where, apart from the air, did this element come from in this experiment?

1 mark

---

- (c) Give **one** safety precaution Marie should take during this experiment.

1 mark

---

---

maximum 5 marks

14. (a) The table gives some of the properties of three substances: water, paraffin wax and naphthalene.

substance	melting point in °C	density (mass of 1 cm <sup>3</sup> in g)
water	0	1.0
paraffin wax	60	0.8
naphthalene	80	1.2

Use the information in the table to help you answer parts (i) and (ii) below.

- (i) Arif placed a ball of naphthalene in a beaker containing water kept at 70°C. On diagram 1, draw the **shape** and **position** of the naphthalene ten minutes later.

2 marks

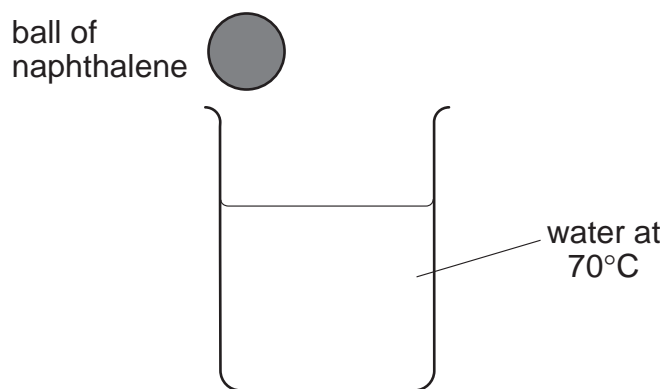

diagram 1

- (ii) Arif repeated the experiment with a similar sized ball of paraffin wax. On diagram 2, draw the **shape** and **position** of the paraffin wax ten minutes later.

2 marks

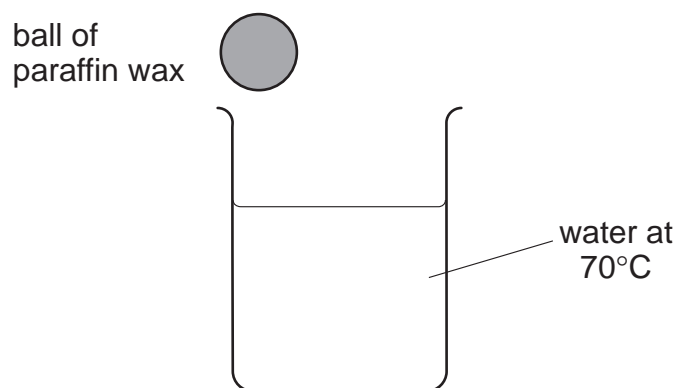

diagram 2

- (b) Arif then melted some crystals of stearic acid in a beaker. He placed a temperature probe in the stearic acid and left the stearic acid to cool. As the stearic acid cooled down its state changed. What was the change in the state of the stearic acid as it cooled?

1 mark

from \_\_\_\_\_ to \_\_\_\_\_

- (c) Arif plotted the following graph.

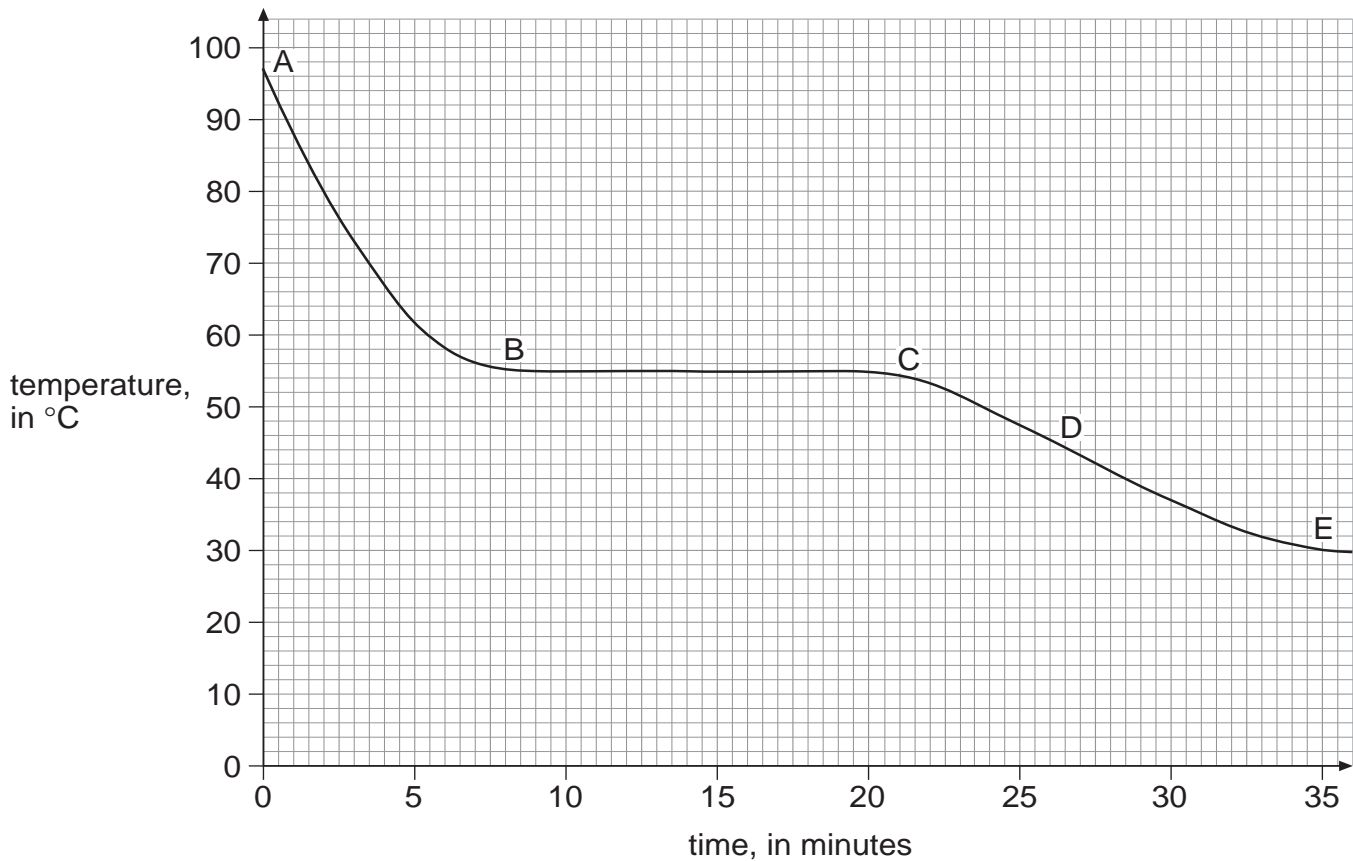

Which letter on the graph shows when the stearic acid **started** to change state?

1 mark

\_\_\_\_\_

maximum 6 marks

15. Jessica was investigating the rusting of iron. She set up five experiments as shown below, and left the test-tubes for three days.

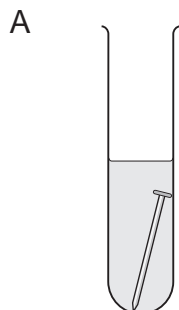

iron nail in distilled water

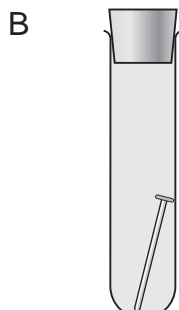

iron nail in tap water which has been boiled to remove dissolved gases

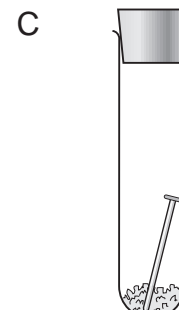

iron nail and a chemical to absorb water vapour

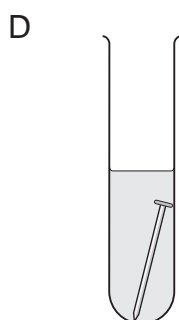

iron nail in sea water

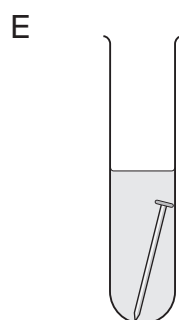

iron nail in vinegar

Jessica wrote the following results in her book.

test-tube	observation
A	nail slightly rusty
B	nail still shiny
C	nail still shiny
D	nail very rusty
E	nail slightly rusty, bubbles of gas seen

---

(a) Explain why the nails had **not** rusted in test-tubes B and C.

2 marks

in test-tube B \_\_\_\_\_

\_\_\_\_\_

in test-tube C \_\_\_\_\_

\_\_\_\_\_

(b) In test-tube E the iron nail reacted with the vinegar.

(i) Is vinegar **acidic**, **alkaline** or **neutral**?

1 mark

\_\_\_\_\_

(ii) When the iron reacted with the vinegar, bubbles of gas were formed.  
What gas was formed?

1 mark

\_\_\_\_\_

(c) Before putting the iron nail in test-tube D, Jessica weighed the nail.  
After three days she dried and weighed the nail **and** the rust which  
had formed.

(i) How did the total mass of the nail and rust compare to the mass of  
the nail at the beginning?

1 mark

\_\_\_\_\_

(ii) Give the reason for your answer.

1 mark

\_\_\_\_\_

\_\_\_\_\_

(d) Jessica concluded that the presence of salt in the water made the nail  
rust more quickly.  
Explain why she drew that conclusion from her experiments.

1 mark

\_\_\_\_\_

\_\_\_\_\_

\_\_\_\_\_

maximum 7 marks

16. Codling moths lay eggs on apple trees. The caterpillars of the codling moth feed on apples. The diagram below shows the life cycle of codling moths.

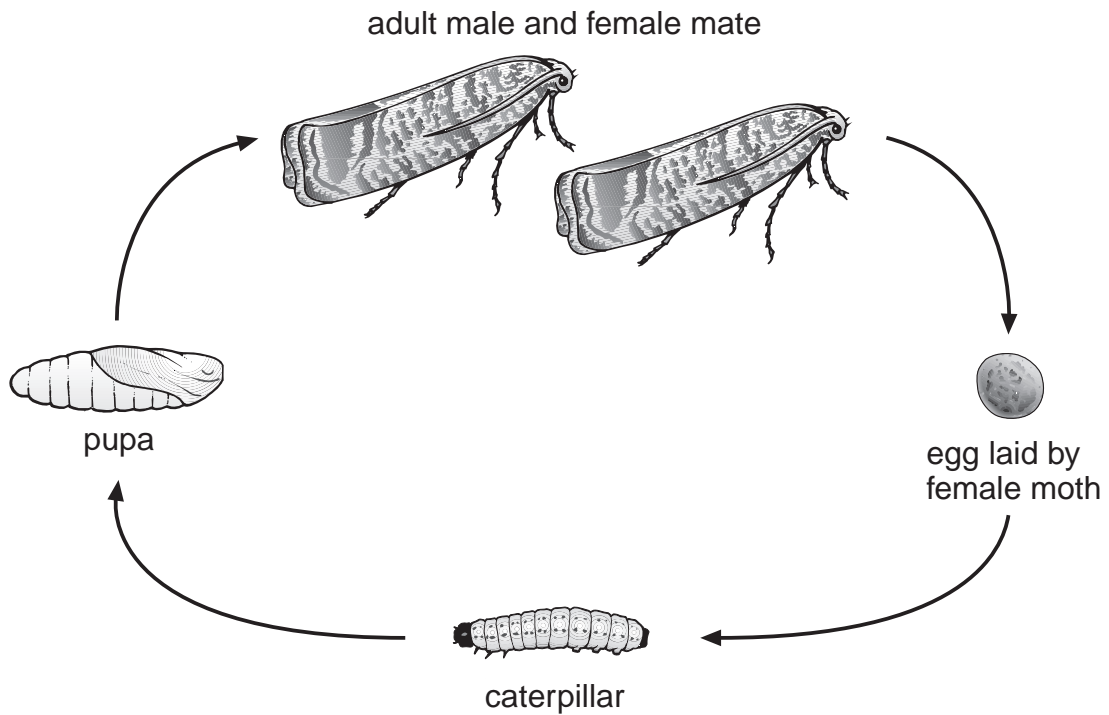

*not to scale*

Apple growers use special traps to catch male codling moths. The traps contain a chemical which female moths produce to attract male moths.

- (a) (i) Explain why trapping male moths may result in fewer caterpillars the next year.

1 mark

---

---

- (ii) Some apple growers spray their trees with insecticide to kill moths. Other apple growers disagree with this method of control. Suggest **two** reasons for **not** using insecticides.

2 marks

1. \_\_\_\_\_

\_\_\_\_\_

2. \_\_\_\_\_

\_\_\_\_\_

- 
- (b) The female moth lays large numbers of eggs.  
Suggest why this is necessary.

1 mark

---

---

- (c) When the caterpillars are fully grown, they crawl into tiny spaces under the bark of the trees. The caterpillars stay under the bark during the winter and then change into pupae.

- (i) Suggest why more caterpillars and pupae survive when they are under the bark.

1 mark

---

---

- (ii) Some apple growers wrap bands of folded cardboard around the trunks of apple trees, as shown below. Caterpillars crawl into the folds. The cardboard is removed during the winter and destroyed.

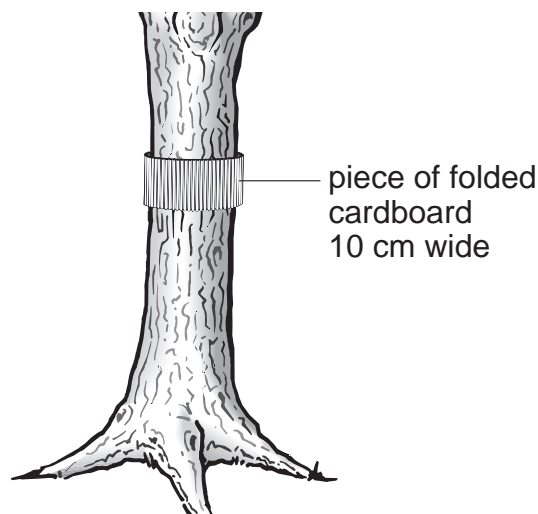

Suggest **one** way in which this helps to protect the next year's apples from damage by caterpillars of codling moths.

1 mark

---

---

maximum 6 marks

17. The diagrams show two plant cells.

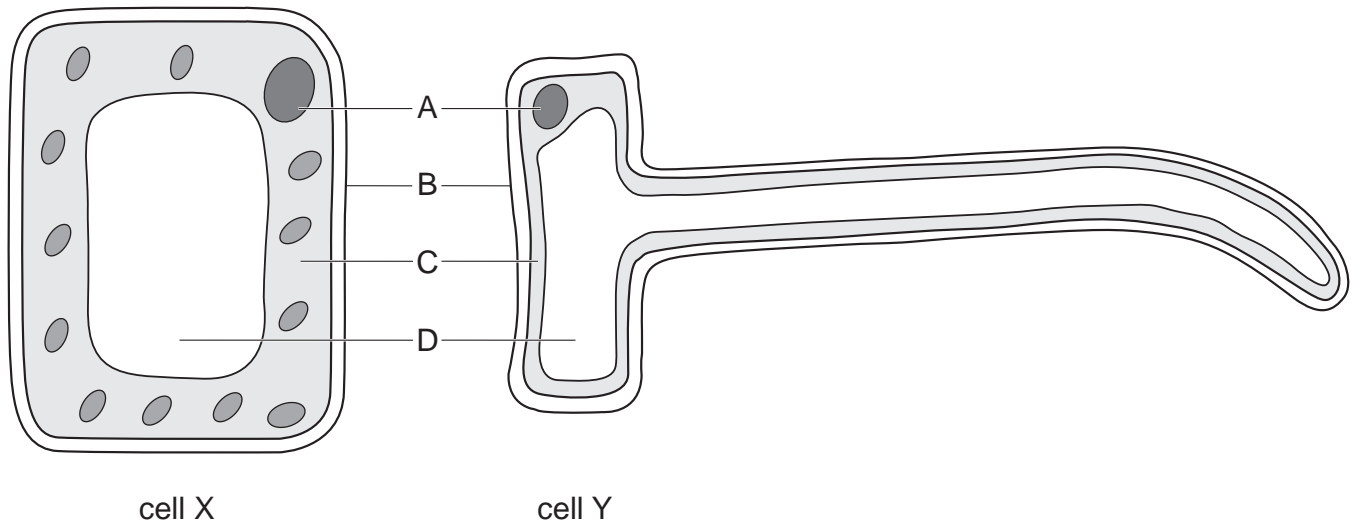

(a) In which part of a plant would these cells be found? *not to scale*

cell X \_\_\_\_\_ *1 mark*

cell Y \_\_\_\_\_ *1 mark*

(b) Give the name of part B. *1 mark*

\_\_\_\_\_

(c) (i) Give the letter which labels the nucleus. *1 mark*

\_\_\_\_\_

(ii) What is the function of the nucleus? *1 mark*

\_\_\_\_\_

\_\_\_\_\_

- 
- (d) (i) How can you tell from the diagram that photosynthesis **cannot** take place in cell Y?

1 mark

---

---

- (ii) Which process takes place in **both** cell X and cell Y?  
Tick the correct box.

1 mark

- egestion
- fertilisation
- pollination
- respiration

maximum 7 marks

**END OF TEST**